



Key Benefits

- ▶ 2U 22" short depth design
- ▶ Light weight only 46.2 lbs / 21 kgs
- ▶ Rugged construction for mobility & durability
- ▶ Built-in solid bearing slide rails
- ▶ Built-in dual stereo speaker (per display)
- ▶ Three LED backlit display selections (4K, FHD, 4:3)
- ▶ DVI-D + VGA video input for FHD & 4:3 (per display)
- ▶ Display port 1.2 video input for 4K (per display)
- ▶ 104-key keyboard with either touchpad or trackball (PS2 / USB)
- ▶ Fits 24" ~ 36" rack via adjustable mounting brackets
- ▶ 2-year standard warranty (upgradable up to 5 years)

Options

- DC power : 12V / 24V / 48V / 125V
- 3G / HD / SD-SDI Broadcast-grade input
- Sunlight readable LCD for 17" FHD & 19" 4:3
- Touchscreen for 17" 4K, 17" FHD & 19" 4:3
- MAC or SUN Micro keyboard options available
- Front USB hub port for device access
- HDMI video input

The MRK 2U dual or triple display console drawer is designed for Command and Control Systems which demand quick deployment of side by side displays.

2U 22" depth platform allows for small size and transit case portability. To ensure chassis ruggedness, mobility and quality, as well as being suitable for harsh environment applications, the MRK drawer is meticulously constructed by a team of experts in our own CNC facilities for such applications.

The key benefit of the MRK series is the choice of different resolution panels including 4K 17", FHD 17" and 19" 4:3 LED backlit displays. Sunlight Readable FHD 17" LCD is also available. 4K 17" displays satisfy the increasing demands for higher graphical and text requirements. A solid 104 key keyboard is integrated with either touchpad or trackball.

Models



LH mounted



RH mounted

4K 17" Display

3840 x 2160 native resolution / Display port 1.2 video input
1920 x 1080 & 1920 x 1200 resolution support

- MRK-K17-3** : Triple display console drawer
- MRK-K17-2L** : Dual display console drawer (LH mounted)
- MRK-K17-2R** : Dual display console drawer (RH mounted)

19" 4:3 Display

1280 x 1024 native resolution / DVI-D + VGA video input

- MRK-19-3** : Triple display console drawer
- MRK-19-2L** : Dual display console drawer (LH mounted)
- MRK-19-2R** : Dual display console drawer (RH mounted)

1080p Full HD FHD 17" Display

1920 x 1080 native resolution / DVI-D + VGA video input

- MRK-F17-3** : Triple display console drawer
- MRK-F17-2L** : Dual display console drawer (LH mounted)
- MRK-F17-2R** : Dual display console drawer (RH mounted)

Product Specifications

LCD Panel	MRK-K17	MRK-F17	MRK-19
Native resolution	3840 x 2160	1920 x 1080	1280 x 1024
Panel size (diagonal)	17.3"	17.3"	19"
Standard Brightness (cd/m ²)	300	400	250
High Brightness (cd/m ²) - Option	/	1000	1000
Contrast ratio (typ.)	1000 : 1	600 : 1	1000 : 1
Colors	16.7 M, 8-bit	16.7 M, 8-bit	16.7 M
Viewing angle (L/R/U/D)	89/89/89/89	80/80/60/80	85/85/80/80
Response time (ms)	Max. 16	5.5	5
Dot pitch (mm)	0.0995	0.1989	0.294
Display area (mm)	382.12H x 214.94V	381.888H x 214.812V	337.92H x 270.33V
Surface treatment	Anti-glare	Anti-glare, Hard-coating	Haze 25%, Hard-coating
Surface hardness	3H	3H	3H
Backlight type	LED	LED	LED
MTBF (hrs)	20,000	50,000	30,000

Video	MRK-K17	MRK-F17	MRK-19
Package	DP 1.2 / HDCP 1.3	DVI-D + VGA	DVI-D + VGA
Option	HDMI 2.0 / HDCP 2.2	HDMI 1.4 / HDCP 1.4	HDMI 1.2 / HDCP 1.1

Capacitive Touch screen Option

	MRK-K17	MRK-F17	MRK-19
Technology	Projected Capacitive		Capacitive
Touch Point	10 point touch standard		Single
Input Type	Finger or Capacitive Stylus		Finger
Resolution	4096 x 4096		2048 x 2048
Touch Point Accuracy	± 2 mm		-
Response Speed	< 5 ms		20 ms
Activation Force	< 5 g		≤ 50 g
Surface Hardness	6H		9H
Light Transmission	> 85%		92% ± 2%
Haze	3%↓		7%
Durability	50 million touches		300 million touches
Top Layer	1.8 mm Glass		Glass
Bottom Layer	0.7 mm Sensor Glass		
Thickness	2.7 mm ± 0.1 mm		2.8 mm ± 10%
Connector	USB		USB Type A
Compatibility	Windows 7 / XP / Linux / Mac		

Resistive Touch screen Option

	MRK-K17	MRK-F17	MRK-19
Technology	5-Wire Resistive		
Touch Point	Single		
Input Type	Finger or Stylus		
Resolution	2048 x 2048		
Response Speed	15 ms		
Activation Force	≤ 50 g		
Surface Hardness	3H		
Light Transmission	80% ± 3%		
Haze	8% ± 3%		
Durability	10 million touches		
Top Layer	ITO Film		
Bottom Layer	ITO Glass		
Thickness	3.2 ± 0.2 mm		2.2 ± 0.2 mm
Connector	USB Type A		
Compatibility	Windows 7 / XP / Linux / Mac		

Product Specifications

Power		MRK-K17	MRK-F17	MRK-19
Input		Auto-sensing 100 to 240VAC, 50 / 60Hz		
Consumption	Screen on	Max. 29W	Max. 25W	Max. 25W
	Power saving	Max. 9W	Max. 4W	Max. 4W
	Power button off	Max. 2W	Max. 1W	Max. 1W

Physical			
Product (W x D x H)	MRK-K17 /	mm	441.6 x 550 x 88
	MRK-F17	inch	17.4 x 21.7 x 3.5
	MRK-19	mm	441.6 x 600 x 88
		inch	22.8 x 23.6 x 7.8
Packing (W x D x H)		mm	580 x 683 x 197
		inch	22.8 x 26.9 x 7.8
Net Weight	MRK-K17 /	Triple display	25.7 kg / 56.5 lb
	MRK-F17	Dual display	21 kg / 46.2 lb
	MRK-19	Triple display	26.7 kg / 58.7 lb
		Dual display	22 kg / 48.4 lb
Gross Weight	MRK-K17 /	Triple display	31.1 kg / 68.4 lb
	MRK-F17	Dual display	26 kg / 57.2 lb
	MRK-19	Triple display	32.1 kg / 70.6 lb
		Dual display	27 kg / 59.4 lb
Chassis color			Dark
Chassis materials			Steel

Compliance	
EMC	FCC & CE certified
Safety	CE / LVD certified
Environment	RoHS2 & REACH compliant

Environment	
Operating temp.	0 to 55°C degree
Storage temp.	-20 to 60°C degree
Operating humidity	20~90%, non-condensing
Storage humidity	5 ~90%, non-condensing
Operating altitude	16,000 ft
Non-operating altitude	40,000 ft
Shock	10G acceleration (11ms duration)
Vibration	10~300Hz 0.5G RMS random vibration

* All dimensions stated are subject to change if options are selected / integrated to base model part codes

Standard Keyboard

Ge G keyboard integrated with touchpad

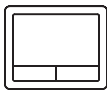
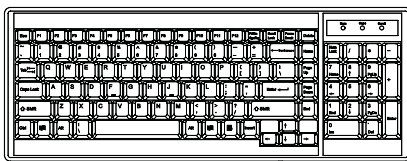

Gb G keyboard integrated with trackball

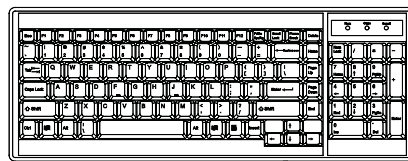

Supporting layouts

America		United States
EMEA		United Kingdom
		Germany
		France
		Spain
		Norway
Asia		Italy
		Russia
		Switzerland
		Netherlands
		Portugal
		China
		Japan
		Korea
		Arabia
		Turkey

Keyboard Options

* US layout only

Me Mac keyboard with touchpad



Se S keyboard with touchpad

Mb Mac keyboard with trackball

Sb S keyboard with trackball



Diagrams (mm)

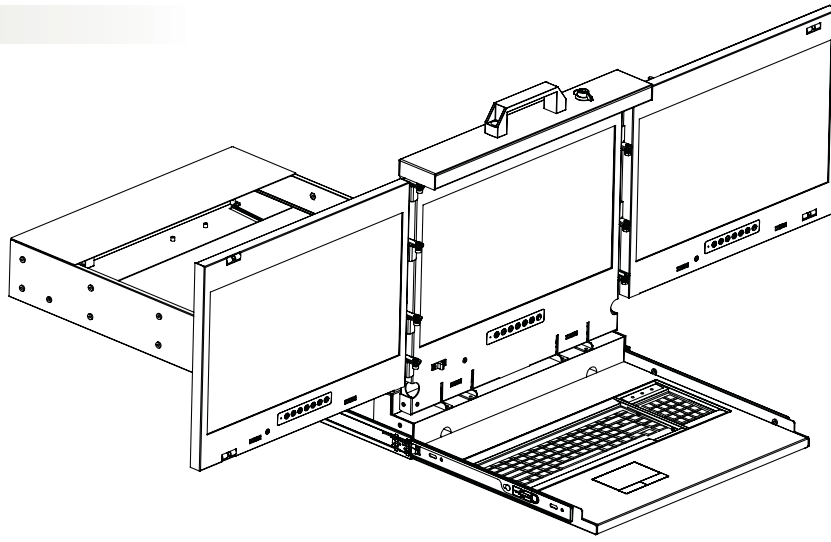

Front View

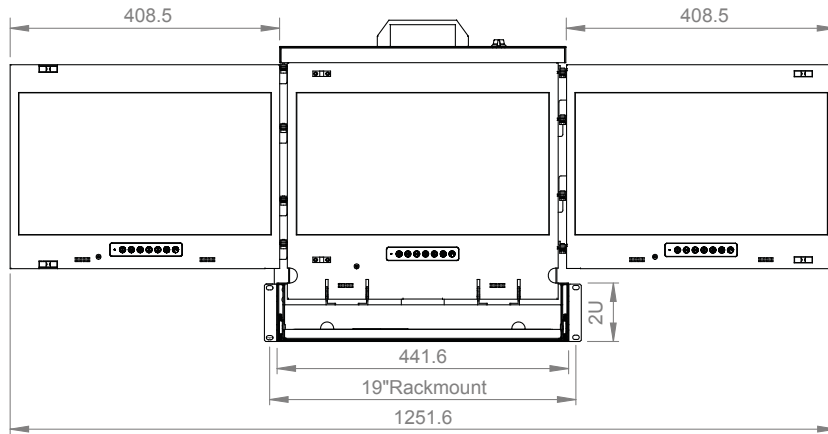

Side View

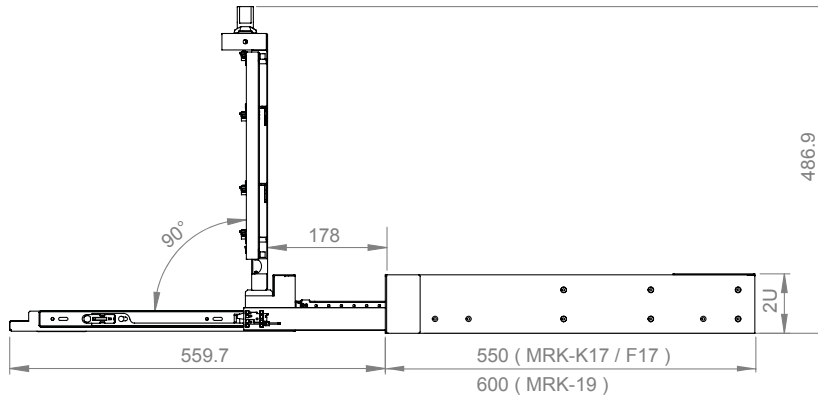

Top View

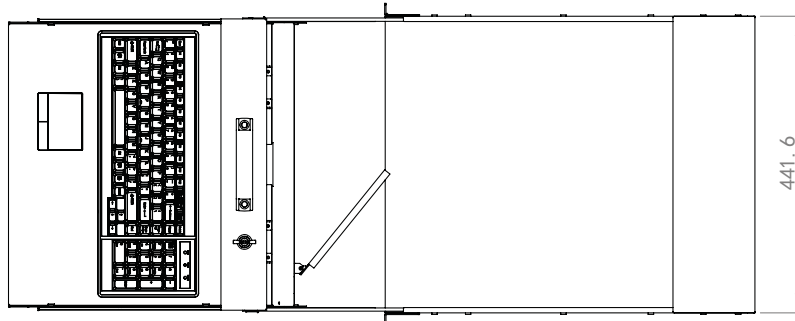

Rear View

MRK-K17

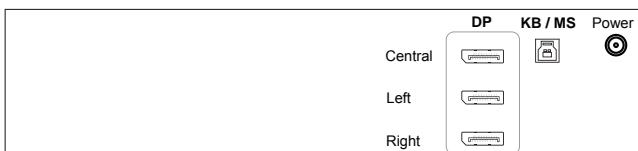

MRK-F17 / MRK-19

