

Top View

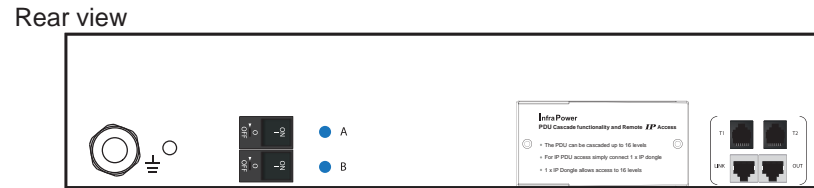

Circuit A

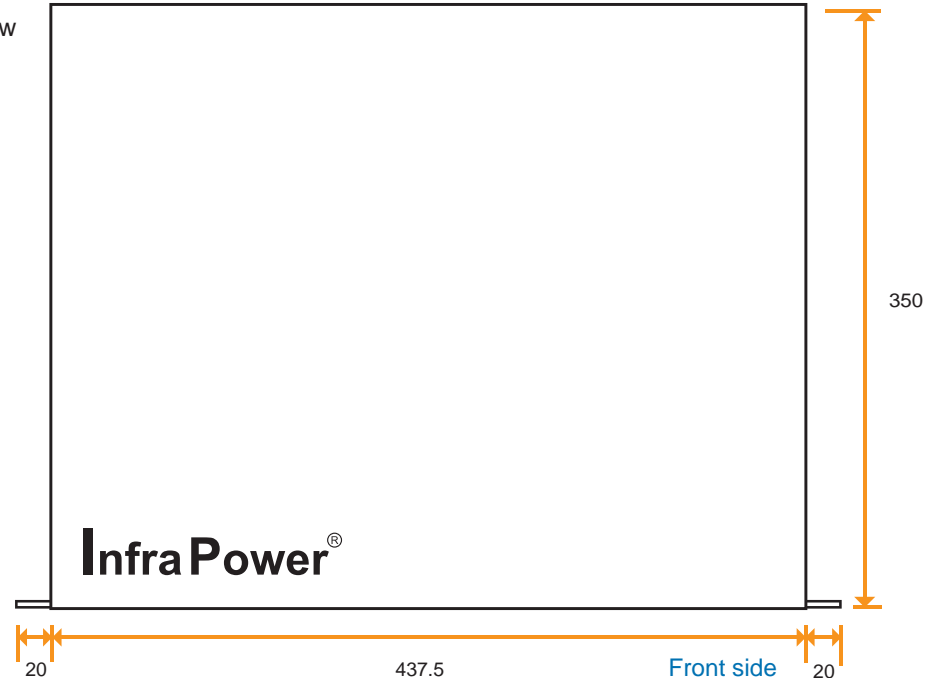
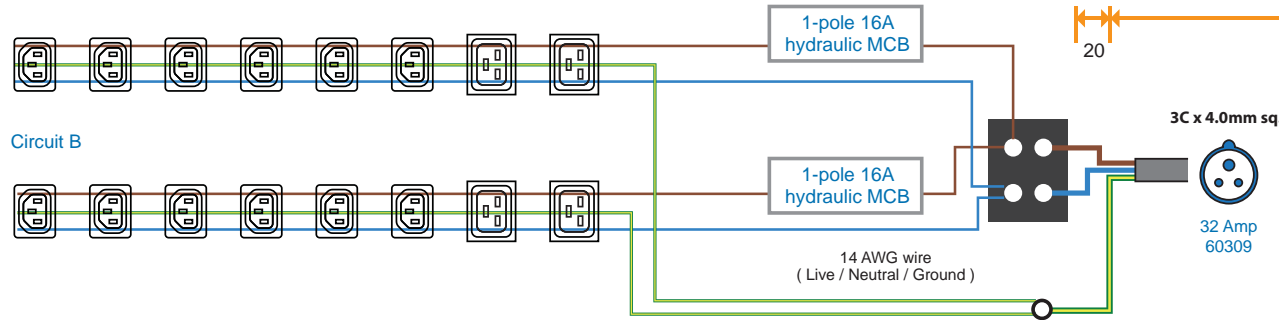

Circuit B

unit : mm

Single phase monitored PDU

Input Rating : 32A, 230V
Outlet : 10A rated C13 x 12
16A rated C19 x 4
Inlet : 32A IEC60309 2P+E plug
Cordset : 3 meter 4.0mm sq. H05V V-F cordset
Protection : 16A single pole hydraulic MCB x 2
Circuit Details : < Circuit A > Output 16A max. C 13 # 1-11 (odd) + C 19 # C1, C3
< Circuit B > Output 16A max. C 13 # 2-12 (even) + C 19 # C2, C4

Meter Features (W monitored PDU)

Local Display : Field replaceable 1.8" color LCD
Bank Measurement : Voltage (V), Current (A), energy (kWh) & power factor
Accuracy : ±1% Billing-grade
IP Access : via IP dongle, one IP Access up to 16 PDU Levels
Cascade : Up to 16 PDU under single IP address via IP dongle
SNMP : V2 / V3 via IP dongle
Sensor Port x 2 : Temp. Sensor / Temp. + Humid. Sensor

EMC Compliance : CE / EMC certified
Safety Compliance : CE / LVD certified
Environment Compliance : RoHS2 & REACH
Operating Temperature : -5 to 60 °C
Storage Temperature : -25 to 65 °C
Operating Altitude : 0 to 2,000 m
Storage Altitude : 0 to 15,000 m
Humidity : 8 to 95% RH, non-condensing

Chassis Material : Steel
Chassis Color : Black
Product Dimension : 437.5 (W) x 350 (D) x 88.9 (H) mm
Net Weight : 5.8 kg
Packing Dimension : 525 (W) x 460 (D) x 130 (H) mm
PDU Gross Weight : 12.9 kg